

**HUSKIE TOOLS, INC.**



**Operating Instruction Manual  
For S-85 Hydraulic Cutters  
With Parts List**



## GENERAL INFORMATION GUIDE FOR S-85 CUTTER

The following steps are guidelines for safe operation of the Huskie cutters. Please take the time to review them as these are helpful hints that have been accumulated over the years.

1. Stay within the maximum cutting limits of each tool as listed on page 10.
2. Try to keep the cutter head clean. When cleaning, use a spray lubricant to avoid a build up of dirt and sand which will damage the cutter head.
3. Stop pumping when the blade reaches the extreme end of its advance. If the material being cut (usually wire rope or soft cables) seems to be cut but does not break free of the tool, this indicates that the blade is jammed on a small piece of cable. Refer to “troubleshooting” on page three to free the blade.
4. All Huskie tools require proper care. Occasional cleaning and degreasing in solvent, and sharpening blade and cutter head, will keep these tools operating without problems.
5. The most common problem encountered is blade breakage. **Ninety-nine percent of all breakage occurs because the cutter head is not securely latched before cutting.** If the latch is not secured, the blade will push open the cutter head and damage both the body head and blade. This causes the outside ear of the blade to break on an angle. In some cases the whole cutter head may crack in half. Cutting material that is not specified may also cause blade damage. In time these blades will fatigue and crack and must then be replaced.
6. There may be a residue of oil present on new tools when they are removed from the original shipping container. This is to protect the tool from corrosion during shipment and storage, and should not be considered defective. The tool can be cleaned with a spray degreaser or soapy water.
7. If tool is jammed, avoid beating directly on the tool with a hammer, especially avoid flattening the piston cylinder. Use a hammer in conjunction with a block of wood or soft material to free the blade.
8. All tools can be reconditioned and overhauled. Call factory and obtain an RGA # for returning tools.

## GENERAL INFORMATION GUIDE FOR CUTTERS

9. If the cutters are used under water, wash them down and lubricate after each use. This whole operation takes less than five minutes. It may be helpful to paint new tools with a light color, corrosion resistant paint.
10. Always return tools to their carrying bag to protect them from sand and dirt. Extra bags can be purchased.
11. Always carry a spare blade, preferably attached to the carrying bag.
12. Use clear hydraulic fluid MV-32 available from your dealer or HTI.
13. When cutting, keep area clear of spectators as hardened metals may fly apart when severed.
14. Always cut the material at a 90 degree angle to the blade. Any other angle may cause the blade and head shear to fracture. See illustration below.

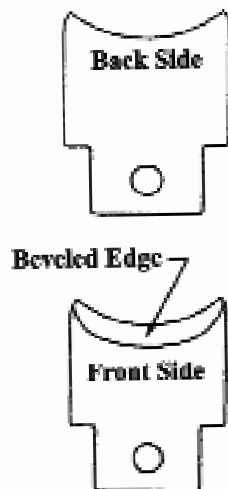
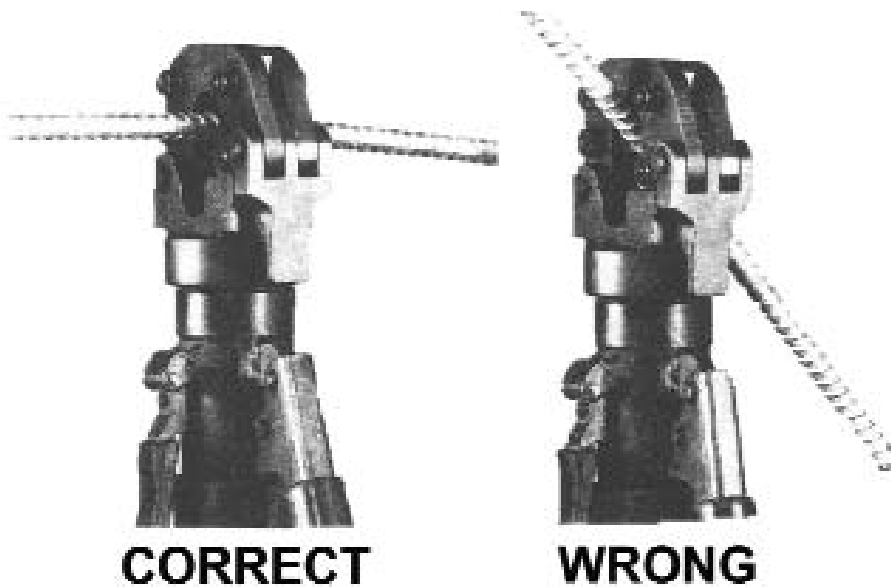

### BLADE SHARPENING INSTRUCTIONS

- 1) Set Blade on Flat Surface With Beveled Edge Facing Down. (See Fig. A)
- 2) Use A Sharpening Stone To Remove All Burrs From Back Surface.



- 3) Use A High Speed Dremel Type Tool To Flatten Top Edge of Blade.  
\*Do Not Sharpen Like A Knife Edge!!

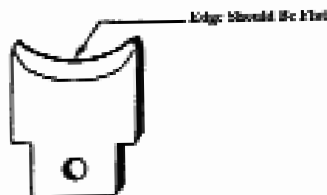

## TROUBLESHOOTING GUIDE

1. **Problem:** Small wire strands or pieces of cable or debris get jammed between the cutter head and blade, not allowing the blade to retract.

**Solution:** A) Hold release lever down while tapping on the ram with a block of wood and a hammer. If this does not work or tool continues to hang up, proceed to step “B”.

B) Remove blade screw and release the ram. Then disassemble cutter head and remove burrs from both blade and head shear, using a flat grinding stone on the rolled edge. **Do not sharpen like a knife – leave cutting edge flat!** See illustration on page 2.

2. **Problem:** Blade is advanced under pressure with no load and the release lever seems to be stuck.

**Solution:** A) Use both hands to depress lever using body weight and the ground or other strong surface for support. If this does not work, proceed to step “B”.

B) Lay tool flat on the ground or other strong surface and hit release lever with a block of wood and a hammer to release pressure.

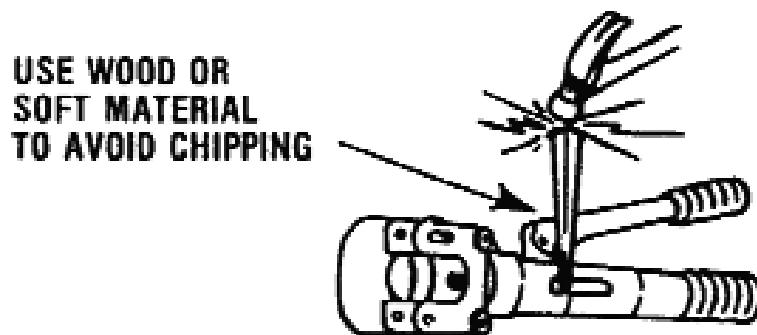

3. **Problem:** Tool will not advance when handle is pumped.

**Solution:** A) Remove body handle and check oil reservoir for proper fluid level. The oil should be to the top of the reservoir when the cap is removed. Be sure the tool is fully retracted before removing cap.

B) After storing for a long period of time, or occasionally when the tool is new, a check ball may be stuck not allowing it to advance. Invert the tool and rap the cutter head sharply on the ground. Do this several times, then pump handle to advance the blade.

## OPERATING INSTRUCTIONS FOR ALL “S” SERIES HYDRAULIC CUTTERS

1. Before cutting, make sure the material being cut is within the proper cutting capacity of the tool being used.
2. Open cutter head by lifting latch or removing lock pin, depending on the model being used.
3. Insert material between cutter head and blade and secure latch. It is important that you check the latch for proper engagement before continuing with the cut. **Failure to secure the latch can result in severe tool damage and personal injury.**
4. Align the material at a 90 degree angle to the blade. This will ensure a proper cut with minimal distortion. If the material is cut at any other angle, severe blade damage may occur. Refer to diagram on page two for proper alignment.
5. Proceed by pumping handle to advance blade. Once blade has made contact with the material, check alignment once again for proper angle. Continue to pump handle and cut material.
6. Once the cut is made, the release lever on the side of the tool body can be depressed to retract the blade. On the model S-85 cutter, the pump handle must be rotated 90 degrees clockwise and then closed to depress release pin located under the handle.
7. These cutters do not have a by-pass cartridge like our compression tools, so they should be released once the cut is made and not continued to be advanced. If the tool is advanced under pressure with no load, it is difficult to release the blade. Refer to the troubleshooting on page three if this condition occurs.
8. Always wear eye protection and any other specified safety equipment when cutting. Be sure surrounding area is clear, as hardened metals may fly apart when severed.
9. **For EHS guy wire or bridge strand, use models S-24CC or S-32CC only!** The use of any other S-series cutter will result in severe blade damage and may cause personal injury.
10. Model S-85 cutter is designed for use on non-ferrous metals only! Do not cut steel or severe tool damage and personal injury may occur.

## S SERIES SPECIFICATIONS

<b>MODEL:</b>	S-16	S-20	S-24	S-32	S-40B	S-55	S-85	S-24CC	S-32CC
<b>OUTPUT:</b>	4.4 ton	4.4 ton	7.8 ton	19.8 ton	6.3 ton	13.0 ton	2.7 ton	7.8 tpm	19.8 ton
<b>WEIGHT:</b>	6 lbs.	6 lbs.	9 lbs.	21 lbs.	12 lbs.	17 lbs.	15 lbs.	9 lbs.	23 lbs.
<b>LENGTH:</b>	15"L	15"L	17"L	27"L	23"L	24"L	26"L	17"L	27"L
Wire Ropes	16mm 5/8"	20mm 3/4"	22mm 7/8"	32mm 1-1/4"	20mm 3/4"	26mm 1"	Do not cut	Do not cut	Do not cut
Soft Steel Bolts	16mm 5/8"	17mm 11/16"	22mm 7/8"	32mm 1-1/4"	20mm 3/4"	32mm 1-1/4"	Do not cut	16mm 5/8"	16mm 5/8"
Rebar, ground, & anchor rod	13mm 1/2"	16mm 5/8"	16mm 5/8"	22mm 7/8"	16mm 5/8"	20mm 3/4"	Do not cut	16mm 5/8"	16mm 5/8"
CU & AL wire	16mm 5/8"	20mm 3/4"	22mm 7/8"	32mm 1-1/4"	40mm 1-1/2"	50mm 2"	45mm 3"		
ACSR (see page 65)	16mm 5/8"	20mm 3/4"	22mm 7/8"	32mm 1-1/4"	40mm 1-1/2"	50mm 2" (1590)	Do not cut		
Standard Guy Wire	13mm 1/2"	14mm 1/2"	16mm 5/8"	22mm 7/8"	16mm 7/8"	20mm 3/4"	Do not cut	14mm 9/16"	22mm 7/8"
Telephone & lead sheathed cable	Do not cut	Do not cut	Do not cut	Do not cut	Do not cut	Do not cut	85mm 3.35"	Do not cut	Do not cut

# MODEL S-85 PARTS DIAGRAM

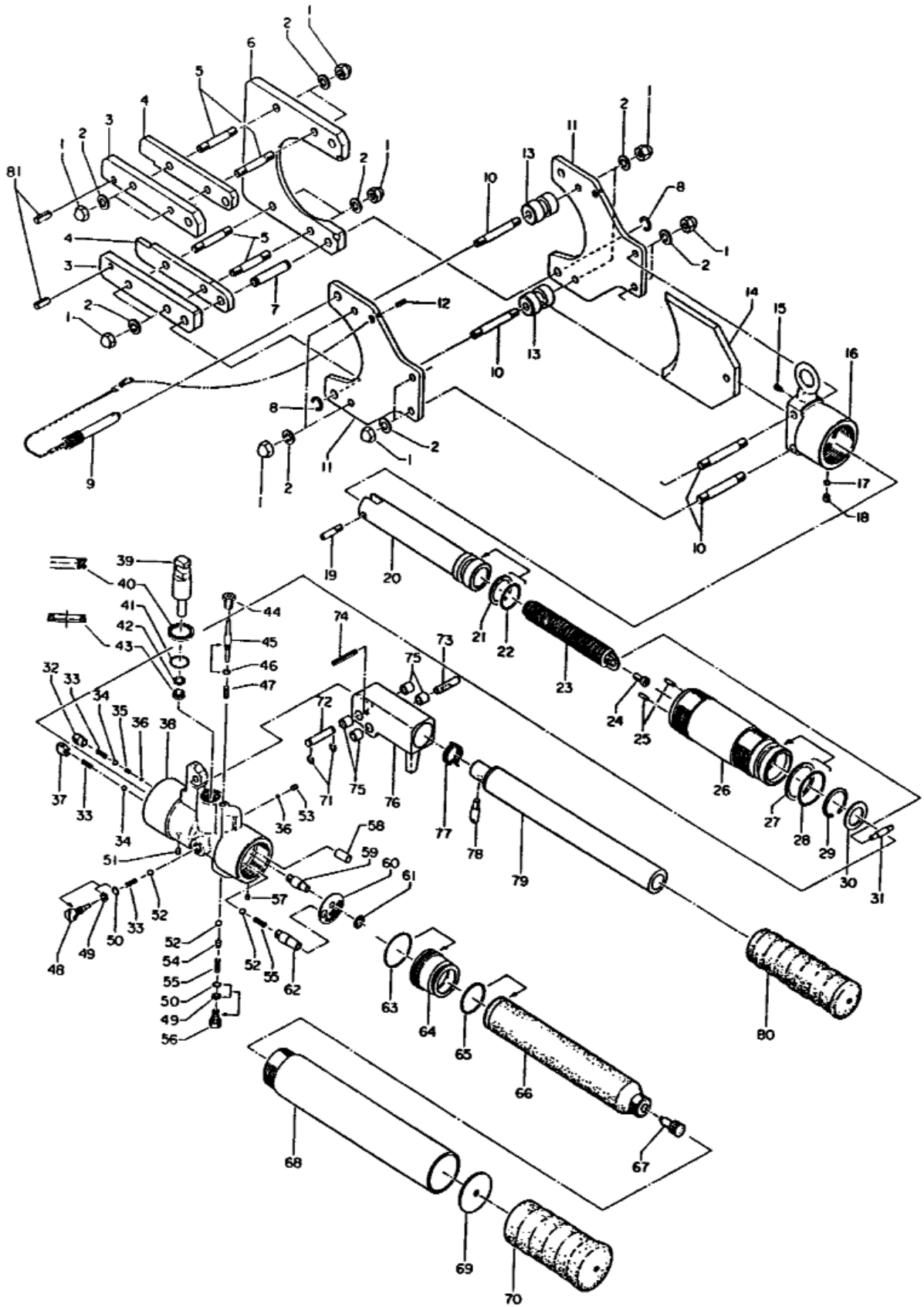





## MODEL S-85 WARRANTY

All Huskie REC-Series battery driven products carry a 5 year warranty, and the ECO-Series carry a 3 year warranty. The BP-70E, BP-70EI, and the BP-70MH batteries carry a 5 year warranty from the date stamped on the battery. The LED indicator on the BP-70-EI battery carries a 1 year warranty from purchase date. Hydraulic hammers carry a one year warranty and all other Huskie products carry a 5 year warranty. Huskie reserves the right to determine all warranty claims. Failure due to misuse, abuse or repairs attempted by anyone other than Huskie Tools, Inc., or an authorized service center render this warranty null and void. Our patented drop-out bypass cartridge can be re-calibrated or tested at no charge for the life of the tool. All factory repaired or reconditioned hydraulic tools carry a one year warranty on parts and labor.

### REPAIR AND WARRANTY CLAIMS

All claims must be sent to Huskie for inspection and authorization. A Return Goods Authorization is required before shipping tools to Huskie. Secure the authorization by telephoning 1-800-860-6170 or writing to Huskie's main office with details of claim. Non-warranty repairs are handled using the same procedure. Repairs exceeding 50% of the cost of a new tool will be advised before repairs are made.

### PLEASE RETAIN FOR YOUR RECORDS

**Purchaser's Name**

---

**Address**

---

**City, State, Zip**

---

**Tool Model Number**

---

**Serial Number**

---

**Date Purchased From**

---

**Purchased From**

---

## MODEL S-85 WARRANTY

### HOW TO GET SERVICE UNDER THE TERMS OF THE LIMITED WARRANTY

Return your product directly to Huskie Tools, Inc. as our representative network is not prepared to service the product under the terms of this warranty.

1. Write, call or fax Huskie stating the tool's purchase date and problem. You will be given a RGA # to assure that your merchandise will be properly handled upon its receipt.
2. CAUTION: Make sure the product is packaged adequately so as to prevent damage or loss during transit. The shipment must be prepaid and we recommend that it be insured. A cover letter indicating the reason for the return should be included in order to facilitate repairs.

-----

**SEND THIS PORTION WITH ANY TOOL WHEN REQUESTING REPAIRS,  
WARRANTY OR RECONDITIONING WORK.**

**PLEASE CALL OR FAX HUSKIE FOR AN RGA#**

**Customer Job No.** \_\_\_\_\_

**Address** \_\_\_\_\_

**City** \_\_\_\_\_ **State** \_\_\_\_\_ **Zip** \_\_\_\_\_

**Tool Model** \_\_\_\_\_

**Warranty Claim** \_\_\_\_\_ **Repair Only** \_\_\_\_\_

**Customer Name:** \_\_\_\_\_

**Phone ( \_\_\_\_\_ )** \_\_\_\_\_

**City** \_\_\_\_\_ **State** \_\_\_\_\_ **Zip** \_\_\_\_\_

**Serial No.** \_\_\_\_\_

**Estimate Required: Yes** \_\_\_\_\_ **No** \_\_\_\_\_

# Huskie



198 N. Brandon Drive  
Glendale Heights, Illinois 60139  
(630) 893-7755 Fax (800) 345-3767  
Toll Free 1-800-860-6170  
<http://www.huskiertools.com>  
[info@huskiertools.com](mailto:info@huskiertools.com)