

MODEL REC-3410 PARTS DIAGRAM

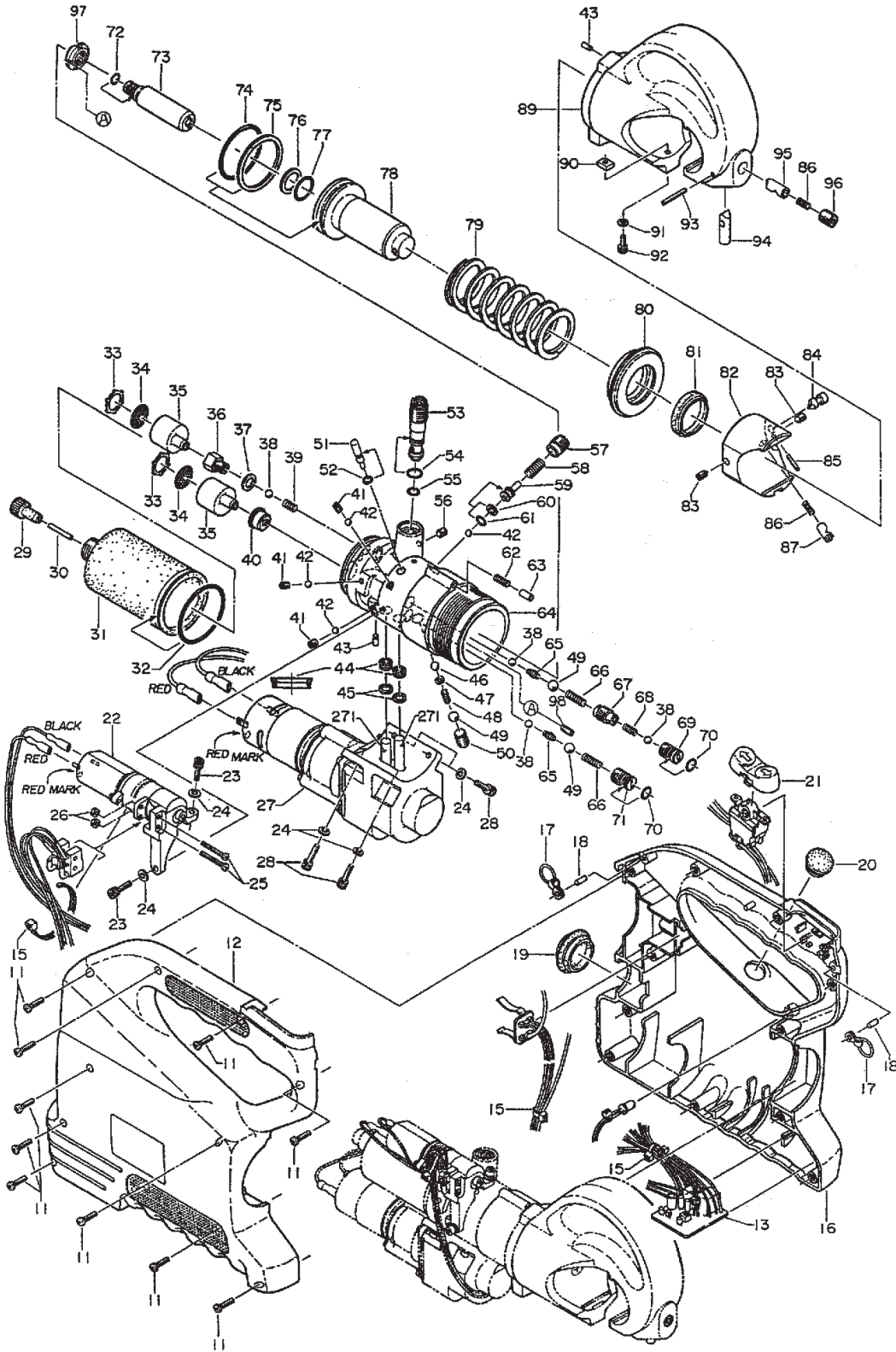

MODEL REC-3410 PARTS LIST

NO.	DESCRIPTION	CODE	QTY	NO.	DESCRIPTION	CODE	QTY
11	M4 X 15 Screw	R150-01	10	60	P-5 Back-Up Ring (B.C.)	E3-126	1
12	Housing (R)	351-01	1	61	P-5 O-Ring	5N-35	1
13	Control Unit	351-02	1	62	Spring (371)	51-17	1
15	Binder	HR-30	3	63	Stopper Pin	351-16	1
16	Housing (L)	351-03	1	64	Body	351-17	1
17	Hanging Ring Ass'y	101A	2	65	Spring (66)	85-40	2
18	4 X 12 Parallel Pin	351-04	2	66	Spring (67)	85-39	2
19	Oil Feed Cap	351-05	1	67	Valve Screw (2)	351-18	1
20	Cartridge Cap	ROB-103	1	68	Spring (340)	51-27	1
21	Switch Knob	351-06	1	69	Valve Screw (3)	351-19	1
22	Release Unit	351-07	1	70	P-7 O-Ring	16-60	2
23	M4 X 10 Screw	351-08	2	71	Valve Screw (1)	R510A-09	1
24	M4 Flat Washer	16-81	6	72	S-5 O-Ring	351-20	1
25	M2.3 X 25 Screw	ROB-86	2	73	Inner Pipe	341-01	1
26	M2.3 Hex Nut	P500-22	2	74	P-41 O-Ring	L100-23	1
27	Power Unit	351-09	1	75	P-41 Back-Up Ring (B.C.)	16B-04	1
28	M4 X 14 Screw	ROB-128	4	76	P-16 Back-Up Ring (B.C.)	22-24	1
29	Reservoir Cap	410-55	1	77	P-16 O-Ring	22-25	1
30	Magnet	ROB-25	1	78	Ram	341-02A	1
31	Oil Reservoir (37)	351-10	1	79	Spring (596)	341-03	1
32	P-40 O-Ring	700S-27	1	80	Guide Ring	341-04	1
33	SI-20 Ring	410-74	2	81	SER-30 Scraper	R510-03	1
34	Filter Screen	410-73	2	82	Ram Head	341-05A	1
35	Strainer	9H-43A	2	83	M5 X 8 Screw (C.P.)	P55A-02	2
36	Strainer Bushing (1)	351-11	1	84	Die Release Pin	430-21	1
37	Copper Gasket (20)	100W-17	1	85	2.5 X 14 Drive Pin (BW)	410-11	1
38	3/16" Ball	16-49	4	86	Spring (177)	410-01	2
39	Spring (340)	51-27	1	87	Retainer Pin (B)	410-12	1
40	Strainer Bushing (2)	ROB-82	1	89	Head	341-07	1
41	M5 X 5 Screw (F.P.)	510A-05	3	90	Key	410-08	1
42	5/32" Ball	22-21	4	91	M4 Lock Washer	410-07	1
43	3 X 8 Dowel Pin (D)	610F-11	2	92	M4 X 10 Screw	410-06	1
44	PS-8 Pent Seal	16-44	2	93	2.5 X 25 Drive Pin (BW)	410-04	1
45	P-8 Back-Up Ring (B.C.)	85-33	2	94	Die Release Pin (A)	410-03	1
46	7/32" Ball	16-26	1	95	Retainer Pin (A)	410-02	1
47	M3 Flat Washer	16-38	1	96	M10 X 10 Screw (F.P.)	16-41	1
48	Spring (76)	16-39	1	271	Pump Piston (2)	P500-10	2
49	9/32" Ball	16-40	3				
50	M10 X 12 Screw (F.P.)	40-47	1				
51	Release Pin	351-12	1				
52	P-3 O-Ring	16-36	1				
53	Valve Cartridge	R510-18A	1				
54	S-9 O-Ring	410-71	1				
55	P-8 O-Ring (B)	700S-15	1				
56	M5 X 5 Screw	300-73	1				
57	Valve Screw (4)	351-13	1				
58	Spring (595)	351-14	1				
59	Reduction Valve	351-15	1				