

# MODEL PG-610A DIAGRAM

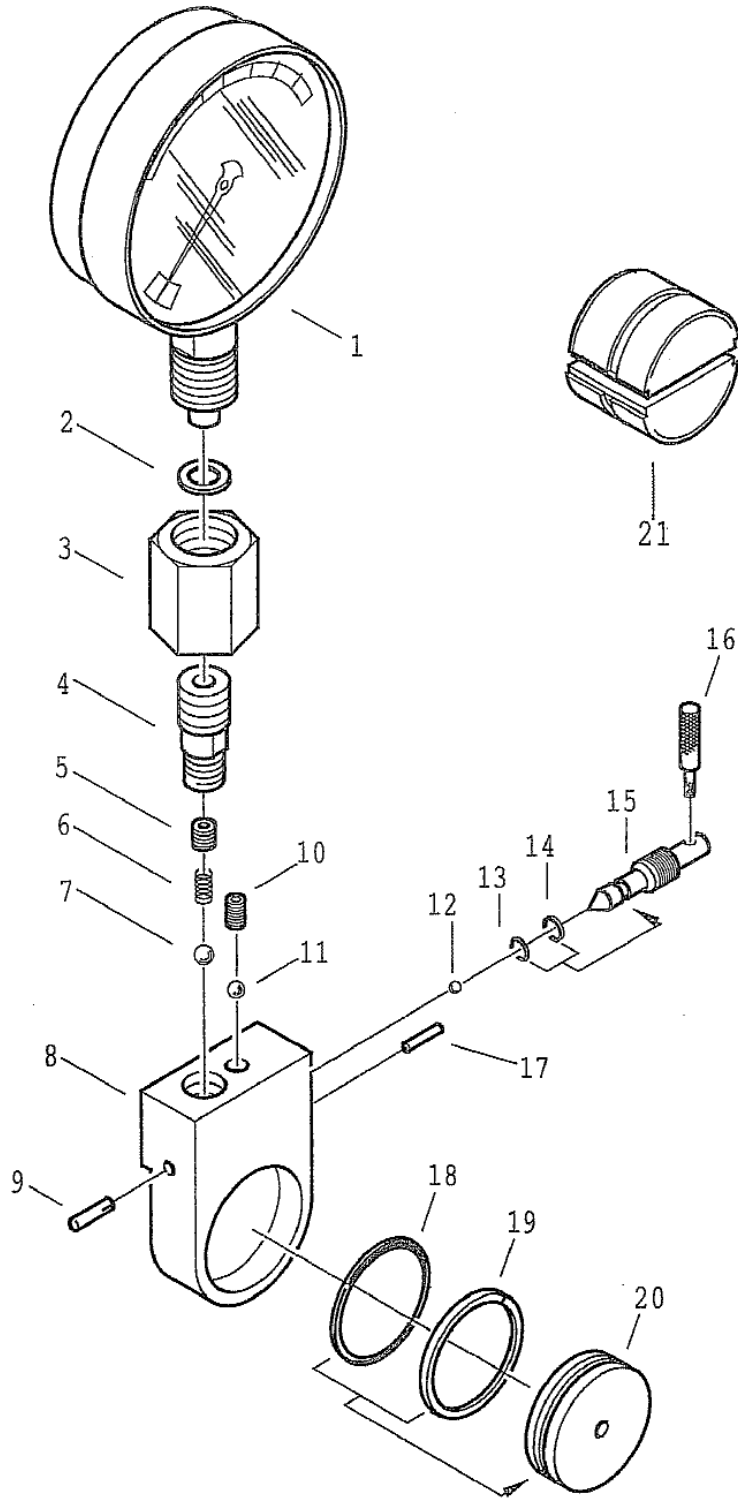

# MODEL PG-610A PARTS LIST

NO	DESCRIPTION	CODE	QTY.
1	Pressure Gauge	PG6A-01	1
2	Copper GAcket (3)	RF-04	1
3	Adapter	PG-02	1
4	Switch Plug	RA-69	1
5	Screw (13)	PG2-04	1
6	Spring (102)	HR-18	1
7	1/4" Ball	26-22	1
8	Cylinder	PG6A-02	1
9	4 X 16 Dowel Pin (G)	24-01	1
10	M6 X 6 Screw (F.P.)	40U-14	1
11	3/16" Ball	16-49	1
12	5/32" Ball	22-21	1
13	P-4 O-ring (U570)	PG15-05	1
14	P-4 Back-Up Ring (B.C.)	410-47	1
15	Release Screw	PG6A-03	1
16	Release Lever	PG6A-04	1
17	2.5 x 14 Drive Pin (AW)	510-10	1
18	KS25 O-ring	PG2-09	1
19	KS-25 Back-Up Ring (BC)	PG2-10	1
20	Ram	PG2-01	1

NO	DESCRIPTION	CODE	QTY.