

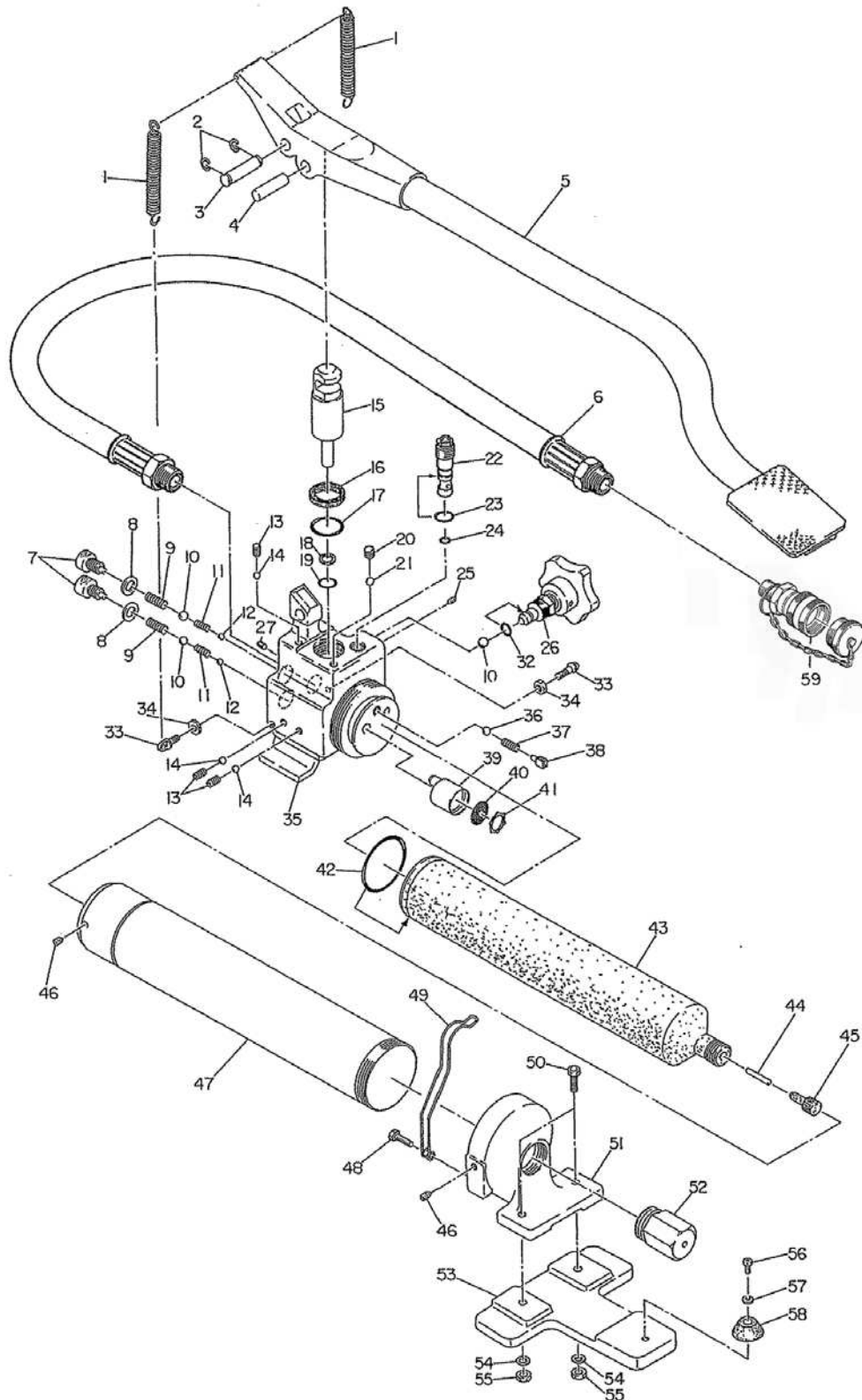

Huskie
TOOLS

MODEL FP-700

Parts Diagram





Huskie
TOOLS

MODEL FP-700

Parts List

NO.	DESCRIPTION	CODE	QTY.
1	SPRING (219)	13S-02	2
2	CE-10 SNAP RING	40-16	2
3	PIN (50)	700S-01	1
4	PIN (51)	700S-02	1
5	FOOT PEDAL ASS'Y	F700A-06	1
6	HOSE 2M	700S-29	1
7	RETAINING SCREW	F700A-07	2
8	COPPER GASKET (7)	E3-68	2
9	SPRING (67)	85-39	2
10	9/32" BALL	16-40	3
11	SPRING (67)	F700A-08	2
12	3/16" BALL	16-49	2
13	M6 X 10 SCREW (F.P.)	RA-71	3
14	5/32" BALL	22-21	3
15	PUMP PISTON	700S-05	1
16	P-26 X-RING	700S-06	1
17	P-26 O-RING	16-55	1
18	P-10A BACK-UP RING (B.C.)	RB-66	1
19	P-10A O-RING	RB-65	1
20	M8 X 8 SCREW (F.P.)	700S-23	1
21	1/4" BALL	26-22	1
22	BYPASS CARTRIDGE	410-36	1
23	S-9 O-RING	410-71	1
24	P-8 O-RING (B)	700S-15	1
25	M5 X 5 SCREW	300-73	1
26	RELEASE KNOB ASS'Y	700A-03	1
27	M4 X 6 SCREW (C.P.)	180-04	1
32	P-5 O-RING	5N-35	1
35	BODY	F700A-11	1
36	7/32" BALL	16-26	1
37	SPRING (43)	85-49	1
38	VALVE SCREW (8)	85-50	1
39	STRAINER	9H-43A	

NO.	DESCRIPTION	CODE	QTY.
40	FILTER SCREEN	410-73	1
41	SI-20 RING	410-74	1
42	P-40 O-RING	700S-27	1
43	OIL RESERVOIR (15)	F700-07	1
44	MAGNET	ROB-25	1
45	RESERVOIR CAP	410-55	1
46	M6 X 6 SCREW (C.P.)	85-41	2
47	RESERVOIR COVER ASS'Y	F700A-10	1
48	M6 X 20 SCREW	RF-05	1
49	SPRING (324)	F700-09	1
50	M6 X 22 SCREW	F700-14	2
51	SUPPORT STAND	F700-10	1
52	END CAP	700S-331	1
53	BASE (B)	F700-12	1
54	M6 LOCK WASHER	16-02	2
55	M6 HEX. NUT	16-01	2
56	M4 X 16 SCREW (NI)	13S-08	1
57	M4 FLAT WASHER	E3-101	1
58	RUBBER SUPPORT	13S-37	1
59	FEMALE COUPLER	FC-8F	1